

C06 Series Current Sensor

The C06 series current sensor provides efficient and precise sensor solutions for AC, DC and pulse currents in industrial, commercial and communications systems. It consists of three main components: an accurate low-temperature drift linear hall sensor, a flux collector and a current transformer. It offers markedly low resistance, reducing power loss and temperature drift to deliver exceptional performance.

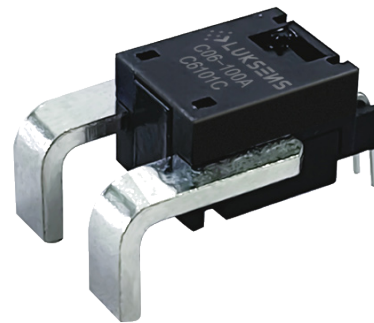

Features

- Non-contact measurement of high current
- Output voltage proportional to carried current
- Max. nominal range $\pm 400\text{A}$ (DC or AC peak)
- Ratio metric output from supply voltage
- Electrical isolation between the primary conductor and the sensor output
- Superior temperature stability and linearity
- High frequency bandwidth 120kHz
- Compact size for applications with limited space
- RoHs compliance (Lead-Free)

Applications

- HVAC
- Converters
- Intelligent power/battery management systems
- Welding applications
- Variable speed drives
- Combiner Boxes

Advantages

- Accurately measures AC, DC and pulse currents
- Fast response 3.5 μs , minimal noise output
- No insertion losses
- High immunity from external interference
- Excellent current overload capacity
- High ESD sensitivity (Human Body Model) 4kV

Standards

- EN 50178:1997
- IEC 61010-1:2010
- IEC 62109-1:2010

Absolute maximum ratings

Symbol	Parameter	Min.	Max.	Unit
$V_{DD\ max.}$	Maximum supply voltage (not destructive)	-0.3	6.5	V
I_{pm}	Maximum measuring current	-400	400	A
T_{pc}	Primary conductor temperature		120	°C
T_A	Ambient operating temperature	-40	105	°C
T_s	Storage temperature range	-40	105	°C
$V_{ESD-HBM}$	ESD sensitivity HBM (Human Body Model)		4	kV

Stresses above these ratings may cause permanent damage. Exposure to absolute maximum ratings for extended periods may degrade reliability.

Specifications ($T_A = 25^\circ\text{C}$, $V_{DD} = 5.0\text{V}$)

Symbol	Parameter	Test condition	Min.	Typ.	Max.	Unit
V_{DD}	Supply voltage		4.5	5	5.5	V
I_C	Current consumption	$I_P=0\text{A}$ without load		6.5	11	mA
I_{pm}	Current nominal measuring range	C06-50A X X X X	-50		50	A
		C06-50AU X X X X	0		50	
		C06-100A X X X X	-100		100	
		C06-100AU X X X X	0		100	
		C06-150A X X X X	-150		150	
		C06-150AU X X X X	0		150	
		C06-200A X X X X	-200		200	
		C06-200AU X X X X	0		200	
		C06-250A X X X X	-250		250	
		C06-250AU X X X X	0		250	
		C06-300A X X X X	-300		300	
		C06-300AU X X X X	0		300	
		C06-400A X X X X	-400		400	
		C06-400AU X X X X	0		400	

Specifications ($T_A = 25^\circ\text{C}$, $V_{DD} = 5.0\text{V}$)

Symbol	Parameter	Test condition	Min.	Typ.	Max.	Unit
R_L	Output load resistance	V_{OUT} to GND	5			k Ω
C_L	Output load capacitance	V_{OUT} to GND		1	10	nF
V_O	$V_{OUT} (@I_p=0A)$	C06-50...400A	2.48	2.5	2.52	V
		C06-50...400AU	0.48	0.5	0.52	V
G	Nominal sensitivity (customized available)	C06-50A X X X X	39	40	41	mV/A
		C06-100A X X X X	19.5	20	20.5	
		C06-150A X X X X	13	13.33	13.6	
		C06-200A X X X X	9.75	10	10.25	
		C06-250A X X X X	7.8	8	8.2	
		C06-300A X X X X	6.47	6.67	6.87	
		C06-400A X X X X	1.95	2	2.05	
		C06-50AU X X X X	78.0	80	82.0	
		C06-100AU X X X X	39	40	41	
		C06-150AU X X X X	26.0	26.67	27.34	
		C06-200AU X X X X	19.5	20	20.5	
		C06-250AU X X X X	15.6	16	16.4	
		C06-300AU X X X X	13.0	13.33	13.66	
		C06-400AU X X X X	9.75	10	10.25	
V_{OE}	Offset voltage	$I_p=0A$	-20		20	mV
ϵ_L	Non-linearity error	$\pm I_{PN}$ without offset	-0.8	0.5	0.8	%/ I_{PN}
ϵ_C	Sensitivity error	Full scale of I_{PN} @ $T_A=25^\circ\text{C}$	-1	± 0.5	1	%
		Full scale of I_{PN} @ $T_A=25^\circ\text{C} \dots 105^\circ\text{C}$	-1.25	± 0.7	1.25	%
		Full scale of I_{PN} @ $T_A=-40^\circ\text{C} \dots 25^\circ\text{C}$	-2.5	± 1.5	2.5	%
T_{CVO}	Temperature coefficient of V_O	$T_A=-40^\circ\text{C} \dots 105^\circ\text{C}$	-0.075	0.05	0.075	mV/K
T_{CVOU}	Temperature coefficient of V_{OUT}	$T_A=-40^\circ\text{C} \dots 105^\circ\text{C}$ (except T_{CVOE})	-1.5	1	1.5	%

Specifications ($T_A = 25^\circ\text{C}$, $V_{DD} = 5.0\text{V}$)

Symbol	Parameter	Test condition	Min.	Typ.	Max.	Unit
BW	Frequency bandwidth (-3dB)			120	250	kHz
T_R	Step response to 90% I _{pn}	(Design target)		3	5	μs
R_{PRIMARY}	Primary conductor resistance	T _A =25°C		0.1		mΩ

Insulation characteristics

Symbol	Parameter	Value	Unit	Comment
V₀	Insulation voltage for isolation, 50Hz, 1 min	3000	V	
R_{ISO}	Isolation resistance @500VDC	>500	MΩ	
D-CLE	Clearance	7	mm	Shortest distance through air
D-CRD	Creepage distance	7	mm	Shortest distance through body

General characteristics

Symbol	Parameter	Value	Unit	Comment
m-HSE	Housing material	V0		Flame retardant UL 94-V0 (PBT)
m-CDT	Conductor material	H62		
m-FC	Flux collector material	Mn-Zn ferrite or silicon steel		
m	Mass	6	grams	

Functional block diagram

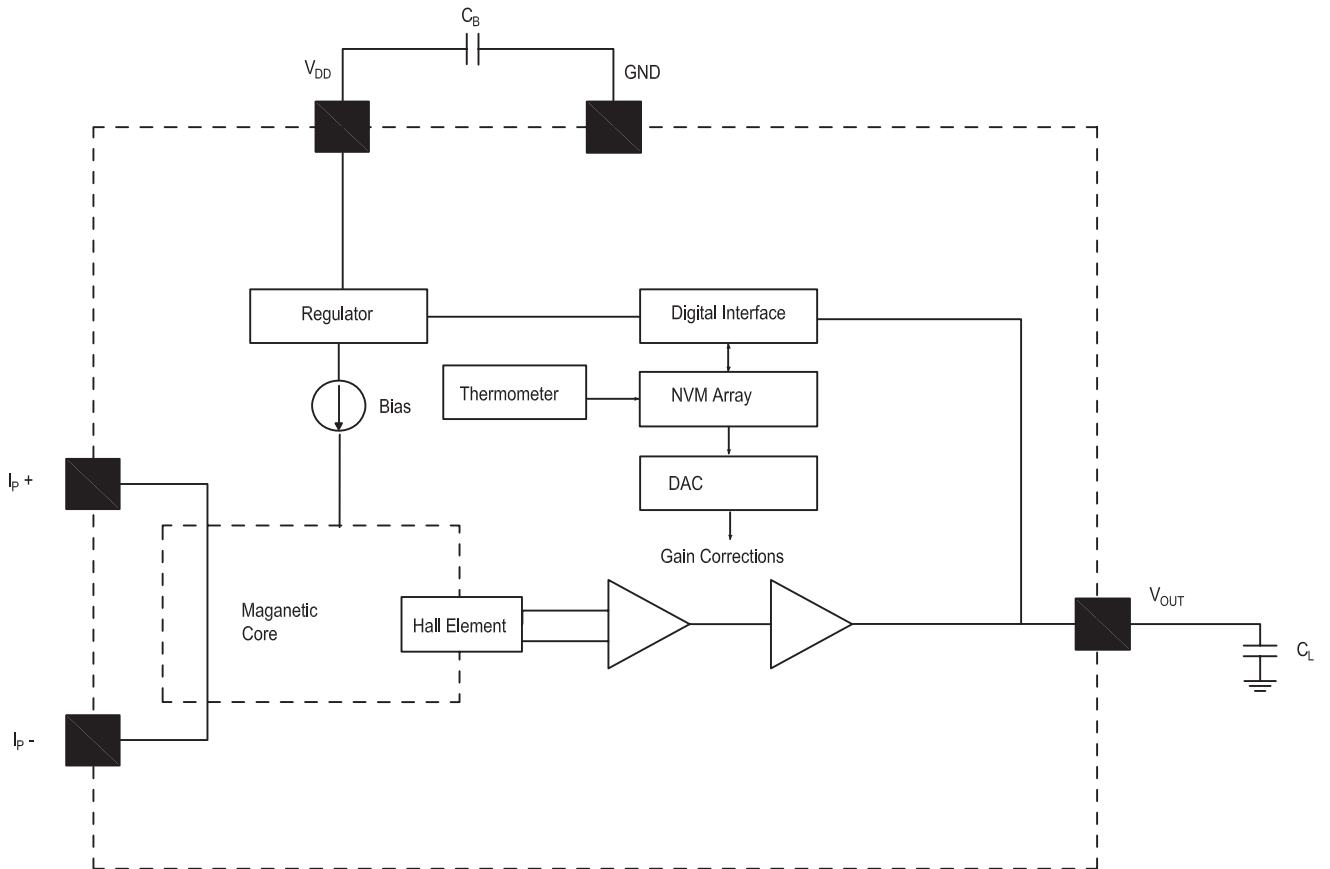

Package Outline Drawings

PCB footprint (mm, general tolerance $\pm 0.05\text{mm}$)

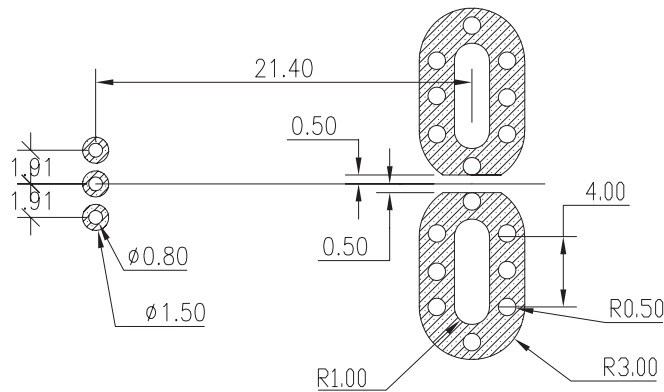

Note:

Maximum soldering temperature 260°C 10s

Maximum PCB thickness 2.4mm

Dimension (mm) : Leadform PAFF

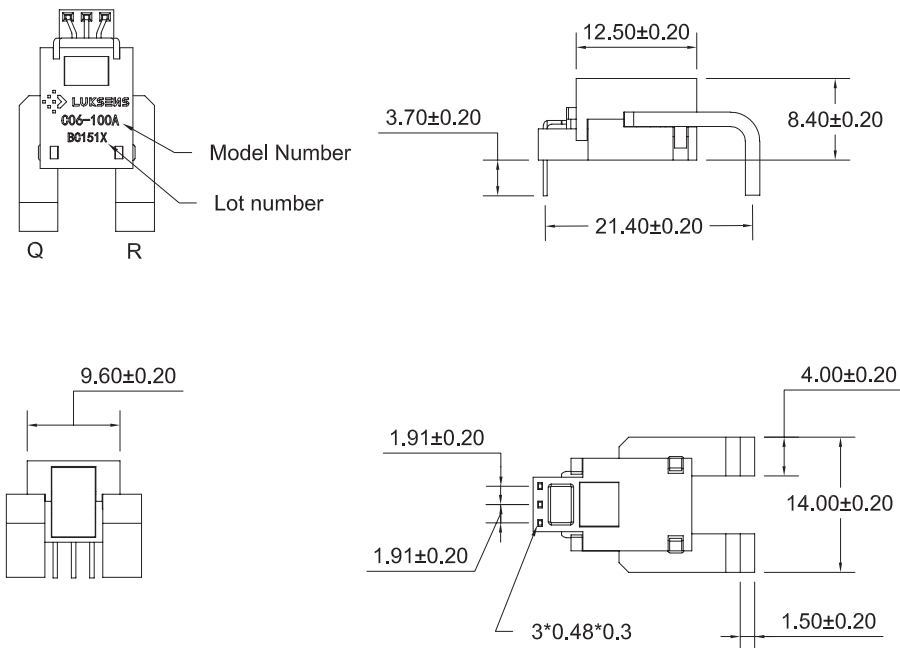

Pin	Symbol
1	V_{DD}
2	GND
3	V_{OUT}
Q	$+I_P$
R	$-I_P$

PCB footprint (mm, general tolerance $\pm 0.05\text{mm}$)

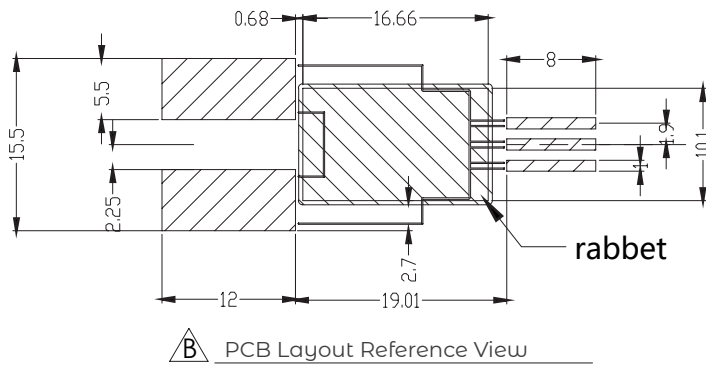

Dimension (mm) : Leadform PASS

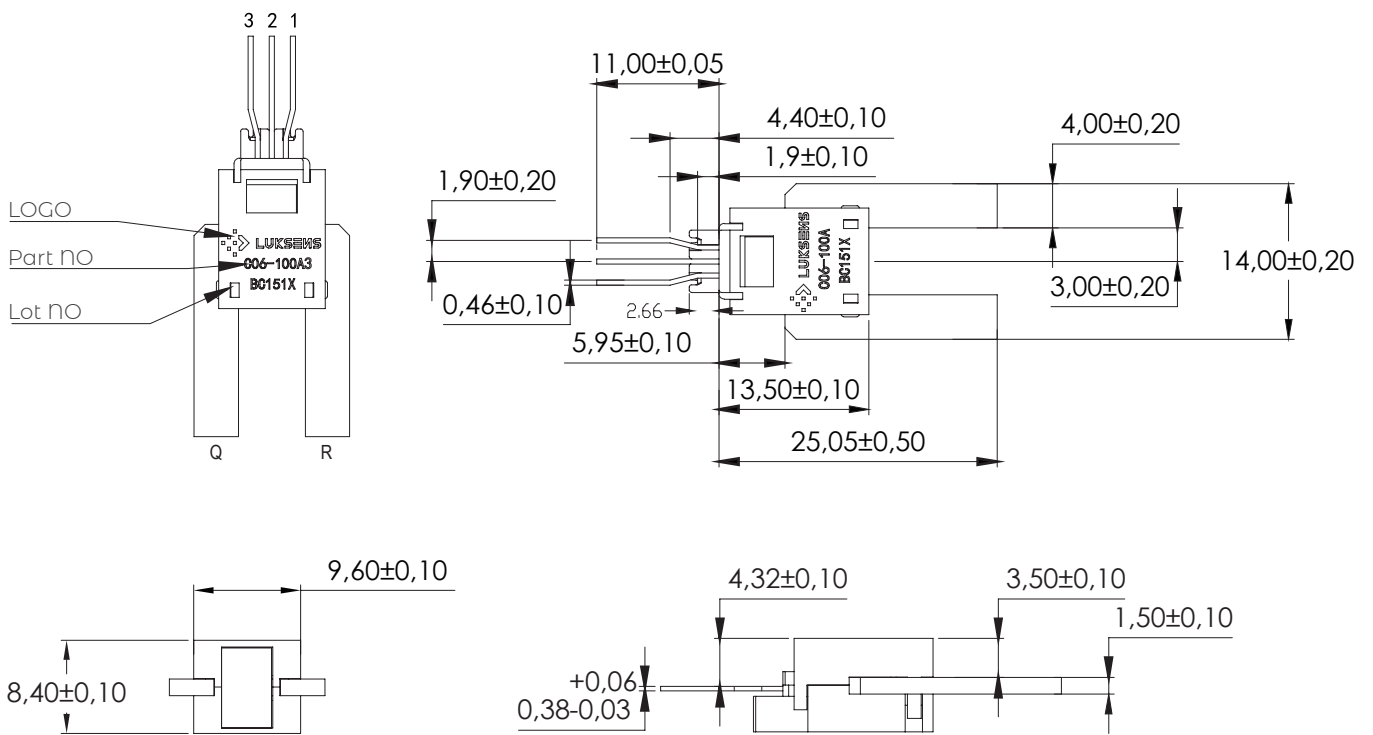

PCB footprint (mm, general tolerance $\pm 0.05\text{mm}$)

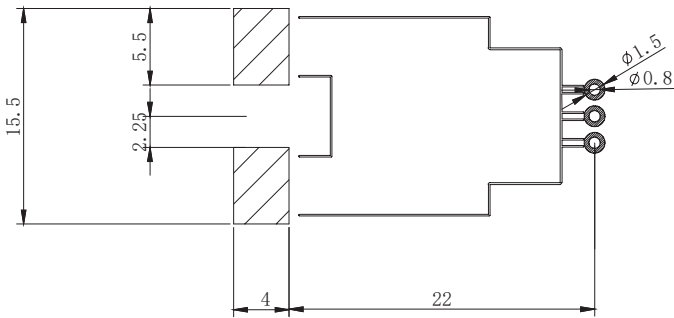

PCB Layout Reference View

Dimension (mm) : Leadform PASF

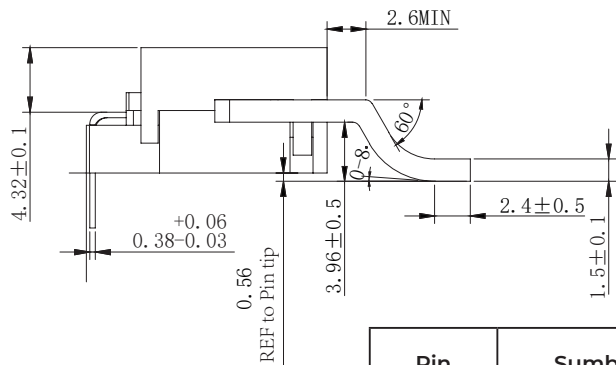
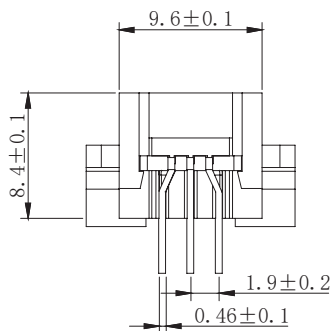
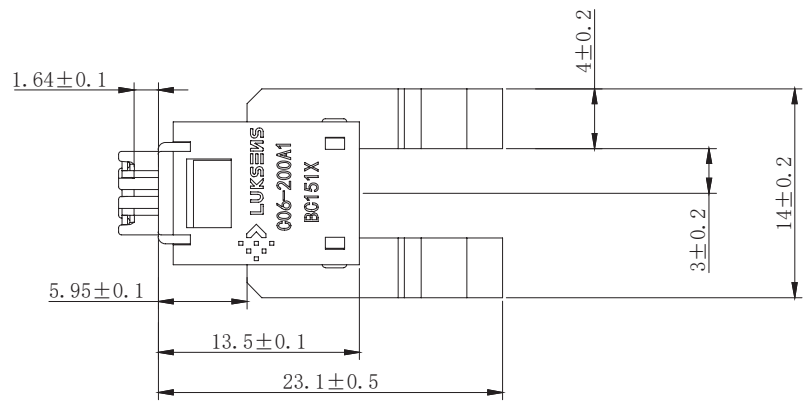
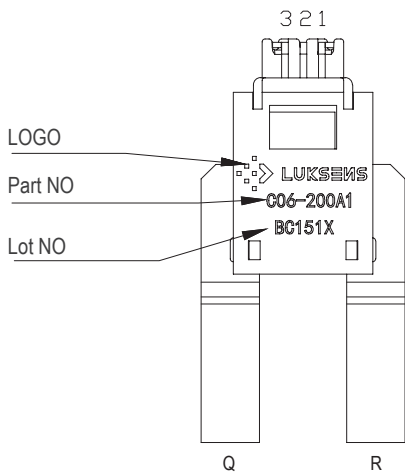

Pin	Symbol
1	V_{DD}
2	GND
3	V_{OUT}
Q	$+I_P$
R	$-I_P$

PCB footprint (mm, general tolerance $\pm 0.05\text{mm}$)

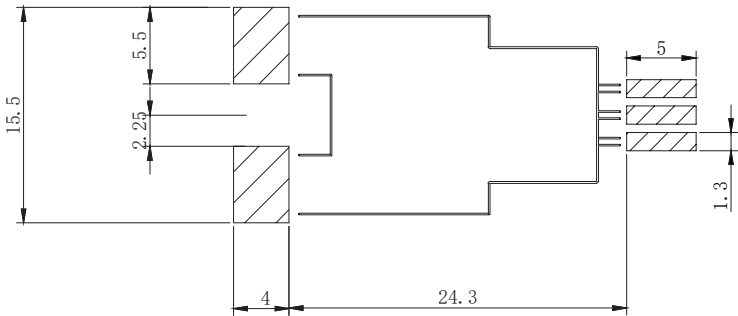

B PCB Layout Reference View

Dimension (mm) : Leadform SMT

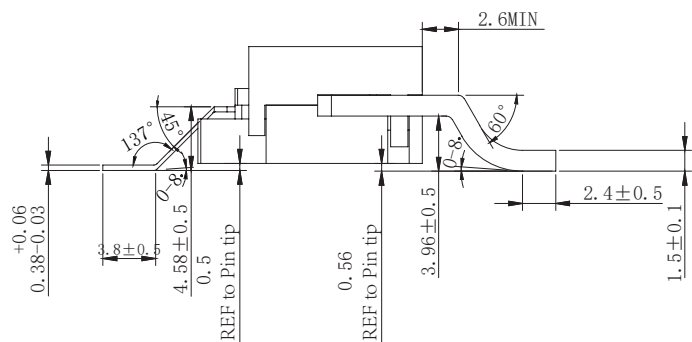
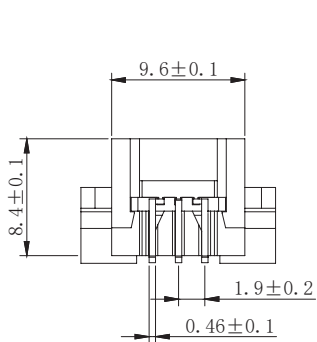
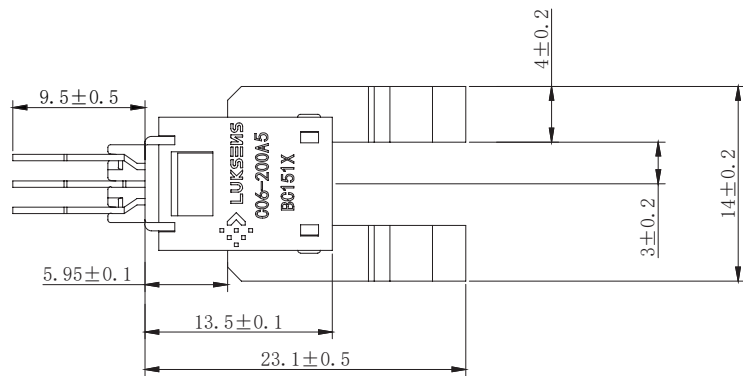
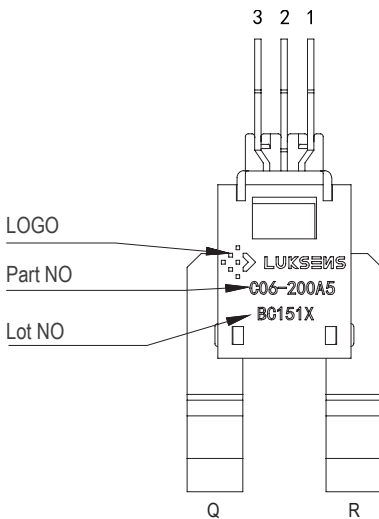

Pin	Symbol
1	V_{DD}
2	GND
3	V_{OUT}
Q	$+I_P$
R	$-I_P$

Name Guide Description

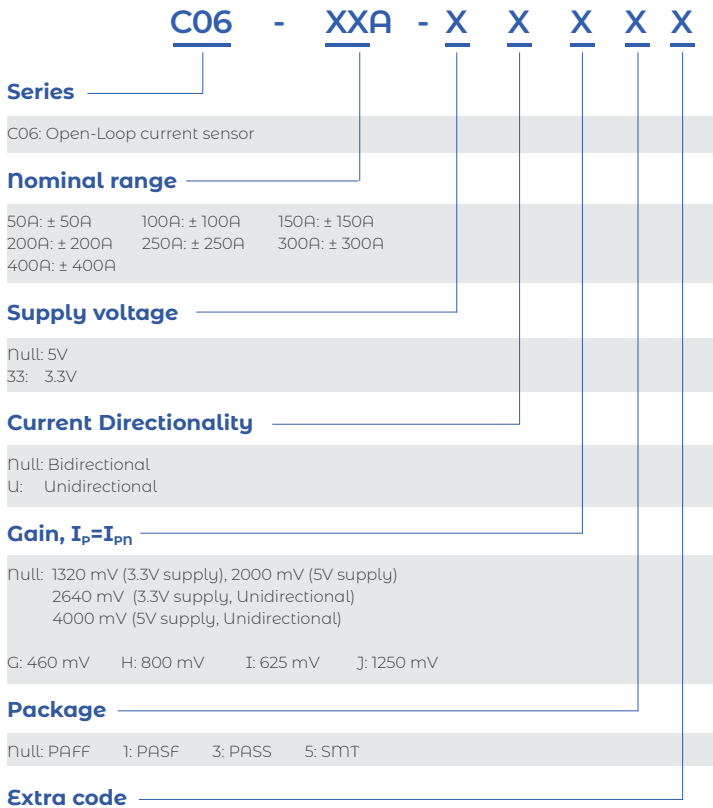

Notes

The content of this document is subject to revision without notice. Luksens shall have no liability for any error or damage of any kind resulting from the use of this document.

Safety and Environment



The product is to be installed by manufacturer trained personnel or competent person trained in accordance with manufacturer installation instructions.

With respect to applicable standards IEC 61010-1/ EN 61010-1 *safety requirements for electrical equipment for measurement, control and laboratory use part 1 general requirements*, the product should be used in limited energy secondary circuits.



Risk of electrical shock

Certain parts of the module can carry hazardous voltage during the operation process of the product because hazardous live voltage of primary conductor, power supply occurs, injury and/or serious damage will be caused if this warning is ignored.

Conducting parts must be inaccessible after installation of the product. Additional protection including shield or protective housing could be used according to IEC 60664 Insulation coordination for equipment within low-voltage supply systems.

Disconnection of the main supply will protect against possible injury and serious damage.



ESD protection

Damage from an ESD event will occur if the personnel is not well grounded when handling.

Important notice

Luksens reserves the right to change the specifications, including all statements and data appearing in Luksens' catalogues, data sheets and advertisements, without notice. Luksens will publish the modified specifications on its website. If such changes to specifications are made, Luksens shall have no obligation to provide the change on Products previously purchased. The information included herein is believed to be accurate and reliable. However, since additional design, measure, production, quality control take effect in the end product, therefore Luksens shall have no liability for any potential hazards, damages, injuries or loss of life resulting from the end product. Luksens products are not to be used in any equipment or system, including but not limited to life support equipment or systems, where failure of Luksens products may cause bodily harm.